

Semi-Automatic Turntable Series

Specifications

- **Production Speed:** Up to 40 LPH
- **Max Load Dimensions:** 52"(w) x 52" (l) x 110" (h)
- **Maximum Load Weight:** 4400 lbs
- **Turntable Height:** 2 7/8"
- **Turntable Diameter:** 65"
- **Turntable Construction:** 3/8" diamond plate steel
- **Turntable Drive Motor:** 1 HP VAC
- **Turntable Speed:** 5 - 15 RPM
- **Frame Construction:** Formed Steel
- **Film Carriage Motor:** 1/2 HP VAC Chain-Driven
- **Pre-Stretch:** Multi-Level Variable 100-400%
- **Containment Force:** Multi-Level Variable
- **Film Threading:** Patented S-Pattern
- **Corner Compensation:** Load Cell
- **Control Panel:** Touch Screen HMI
- **Height Sensing:** Automatic via Photocell
- **Wrapping Menus:** 12 Programmable Menus
- **Utility Requirements:** 110 VAC, 1ph/60Hz (+/-10%)
- **Safety:** Anti-Fall Device & Pressure Activated Safety Stop on Carriage, CE Compliant, UL, CUL
- **Available Options:** Ramp, Roping Device, Auto Film-Cutting Device, Scale Pkg, Top Platen Hold Down, 30" Film Carriage, Extended Warranty, Cold Pkg

Key Features

- ✓ *Cube "SMART Stretch Wrapping" Technology*
- ✓ *Multi-Level Variable Pre- Stretch & Containment Force*
- ✓ *Standard 110" Wrap Height*
- ✓ *Icon Driven Touchscreen*
- ✓ *Auto-Film Clamp (Cut & Weld)*
- ✓ *R-Connect Ready*
- ✓ *Warranty*

ROBOPAC
Innovation driven by values

TECHNOPLAT TECHNOPLAT 708 CW



Layouts

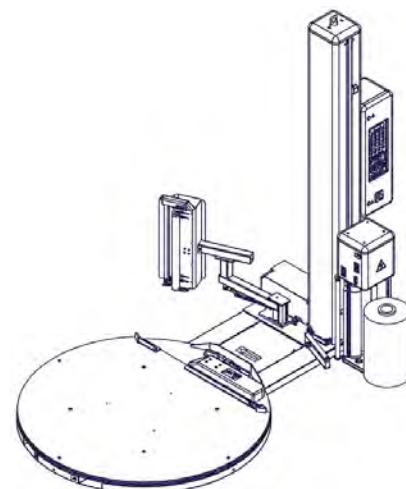
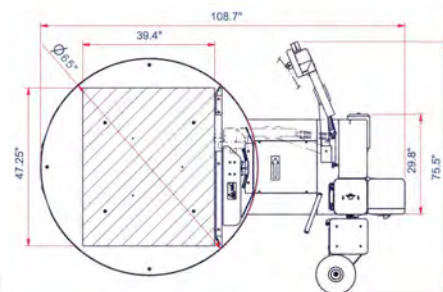
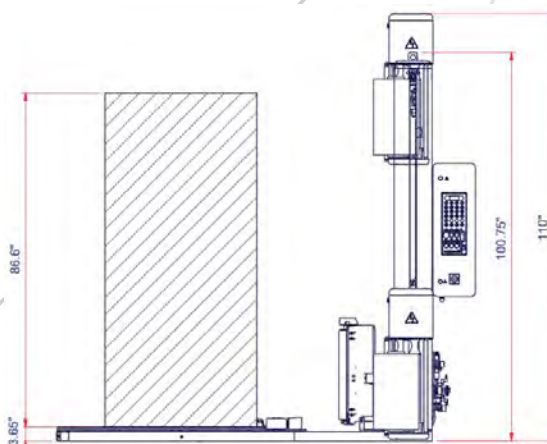

Smart Solutions. Even Smarter Machines.
Innovation | Reliability | Service

www.robopacusa.com | 866.713.7286 | info.usa@robopac.com

