

# HELIX 1

Automatic Rotating  
Arm Stretch Wrapping  
Machine



**ROBOPAC**  
SISTEMI

# overview

The **Helix 1** is a rugged, reliable rotary arm stretch wrapper loaded with features you would expect on more expensive machines.

Robopac utilizes **22" circumference pre-stretch rollers** in the Helix 1's patented S winding pattern roll carriage to deliver 60% more film contact than the W winding pattern (commonly used by competitors). The S pattern delivers better control of film through the roll carriage, higher on load pre-stretch levels and fewer film breaks.

**Innovative VAC motors with Encoders** work with **Motion Control Devices** via the control panel to give you ultimate

control of pre-stretch and containment force.

The **Helix1** is **CE Compliant** and features **Level 3 Safety Circuits**. **Light Curtains are standard**, as are power and air dump interlocks providing you the safest work environment available for your operators.

The system features 15 selectable wrap patterns for each of your load types. Software allows you to adjust all wrapping parameters to meet the specific needs of each load: pre-stretch; containment force (multi-level); top & bottom wraps; wrap arm rotation speed; overlap and overwrap; banding; and roping.

## CUBE Technology (On Helix 1 CT1)

**Multi-Level Variable Pre-Stretch** ensures the best film economy for any load. It allows you to get the highest containment and the best film economy from any stretch film. You can adjust the pre-stretch up to 12 times on each load. **Multi-Level Variable Pre-Stretch Technology** delivers **30% to 55% film savings**.

**Multi-Level Containment Force** setting on the control panel delivers optimal containment force at each level. Containment Force is adjustable up to 12 times on each load.

**Strategic Film Placement** allows you to place the film exactly where it has the most impact on load contain-

ment. This innovative technology allows you to place bands of film or roped film in critical areas of your loads.

**ProActive Corner Compensation** combines the latest in **VAC Motors, Motion Control Devices** and **Encoder Technology** giving you the ability to wrap any load securely without crushing the corners of the load, while increasing containment force.

**Film Break Test Cycle** is standard on the Helix 1 CT1. This **innovative** feature allows the machine to **determine the maximum pre-stretch level** for your film at the **correct containment force for your loads**. This ensures that you always get **the proper containment force and the best film economy**.

## technology

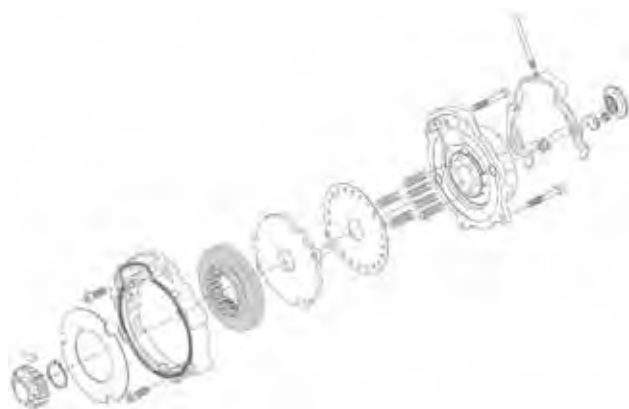

### Self-Braking AC Motors

Special AC Motors with Encoders and Motion Control Devices deliver the most accurate pre-stretch and containment force available.

### Frequency Drive

Variable frequency drive allows you to vary the line speed up to a maximum of 60 feet/min without replacing a single component.

### Conveyors

All conveyor rollers feature reverse motion. Infeed and center feed conveyors are controlled by variable frequency driver. Self-braking motors ensure precise positioning of the pallet.

# specifications

Specifications		
	Helix 1	Helix 1 with CT1
Speed	20 RPM	20 RPM
Support Structure	4 Legged	4 Legged
PLC	AB MicroLogix 1400	AB MicroLogix 1400
HMI	AB PanelView 600 Plus Monochrome	AB PanelView 600 Plus Monochrome
Motors	Bonfiglioli Motors VAC	Bonfiglioli Motors VAC
Roll Carriage	PGSM Roll Carriage	PGSA Roll Carriage
Pre-Stretch Standard	Fixed up to 300%	Variable 150% to 400%
Multi Level Pre-Stretch	Not Available	Up to 12 Levels on each load
Multi Level Containment Force	Up to 12 Levels on each load	Up to 12 Levels on each load
Corner Compensation	Load Cell	Load Cell
Film Test Cycle	Not Available	Standard
Film Cut and Clamp	Cut, Press & Wipe	Cut, Press & Wipe
Conveyor Roller Spacing	4,400 lb Capacity (3 on 3-1/2" centers)	4,400 lb Capacity (3 on 3-1/2" centers)
Galvanized Conveyor Rollers	Standard	Standard
Conveyor Reversing	Standard	Standard
Positioning Control	Self braking AC motors and Encoder Technology	Self braking AC motors and Encoder Technology
Alarm	1 Color Light Stack	1 Color Light Stack
Throughput	55 LPH	55 LPH
Max Load Size	48"L x 48"W x 78.74"H	48"L x 48"W x 78.74"H
Min Load Size	31.5"L x 31.5"W x 20"H	31.5"L x 31.5"W x 20"H
Warranty	3 Year + 10 Year on Ring Gear Bearing and Structural Frame	3 Year + 10 Year on Ring Gear Bearing and Structural Frame
Personnel Safety	Category 3 Safety Circuits with Light Curtains (CE Approved)	Category 3 Safety Circuits with Light Curtains (CE Approved)
ISO 9001	Yes - ISO 9001:2008	Yes - ISO 9001:2008
CE Compliant	Yes	Yes
Auto Roll Changer	Available Option	Available Option
Corner Board Applicator	Available Option	Available Option
Top Sheet Dispenser	2 Options: Mid Wrap and Inline	2 Options: Mid Wrap and Inline



**PGSA Roll Carriage**  
Dual motor roll carriage with motion control devices that allow you to set up to 12 containment force levels at different points on each load. Multi-level variable pre-stretch is standard. And a film break test cycle checks for the maximum pre-stretch the film can deliver.



**PGSM Roll Carriage**  
Single motor roll carriage with fixed pre-stretch provides you up to 12 containment force levels at different points on each load.

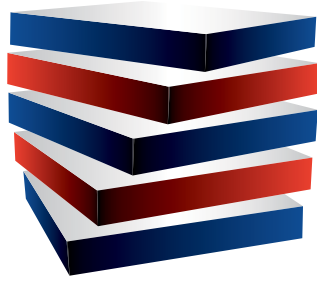

# CUBE TECHNOLOGY

The key to the success of any activity in the manufacturing environment is setting and holding standards. Stretch wrapping is no exception. To successfully wrap your loads and to ensure that they reach your customer in as-made condition, it is critical that you set and hold the proper standards for wrapping each of your loads.

CUBE Key Performance Data. The Helix 1's advanced technology gives you the ability to set different wrapping parameters for each product and load configuration that you produce. Allowing you to customize the wrap pattern to "set the standard" for each type of product that you wrap. Because of the accuracy of the Variable Pre-stretch and Variable Containment Force technology, we can provide accurate and actionable real time performance data. This will ensure that you are indeed "holding the standard" set for each of your products.

We will guarantee the accuracy of our film usage data to within 5% plus or minus. Competitive systems consistently vary more than 30% plus or minus.

Multi-Level Variable Pre-Stretch ensures the best film economy for every load. It allows you to get the highest containment and the best film economy from any stretch film. You can adjust the pre-stretch up to 12 times on each load. The Multi-Level Variable Pre-Stretch Technology delivers 30% to 55% film savings over currently available competitive stretch wrapping systems.

Multi-Level Variable Containment Force setting on the control panel delivers optimal containment force at each level. Containment Force is adjustable up to 12 times on each load.

Strategic Film Placement allows you to place the film exactly where it has the most impact on load stability and containment. This innovative technology allows you to place bands of film or roped film in critical areas of your loads.

ProActive Corner Compensation combines the latest in Servo Motor and Encoder Technology to give you the ability to wrap any load securely without crushing the corners of the load, while increasing containment force. The corner of every load is the biggest constraint to film savings and load containment. Competitive systems deliver 30% to 40% higher containment on the corners of the

load than in the middle causing either repetitive film breaks or load failures due to crushing and collapsing the corners of your boxes.

Film Break Test Cycle is standard on the Helix 1. This innovative feature allows the machine to determine the maximum pre-stretch level for your film at the correct containment force for your loads. This ensures that you always get the proper containment force and the best film economy.

**ProActive Corner  
Compensation combines the latest in Servo  
Motor and Encoder  
Technology to give you  
the ability to wrap any  
load securely without  
crushing the corners of  
the load, while increasing  
containment force.**

# machine layout

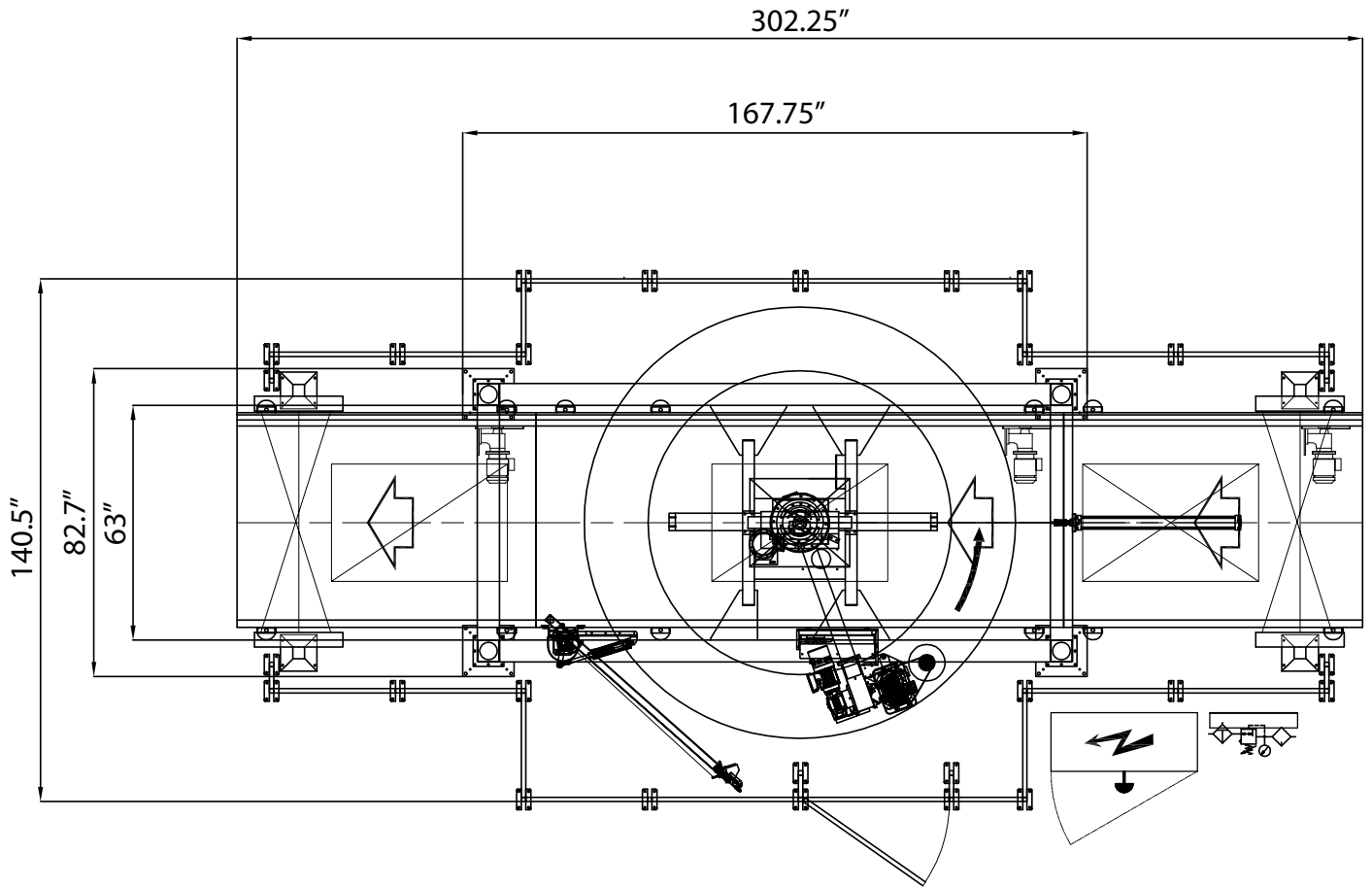

# options

## Top Pressure Platens

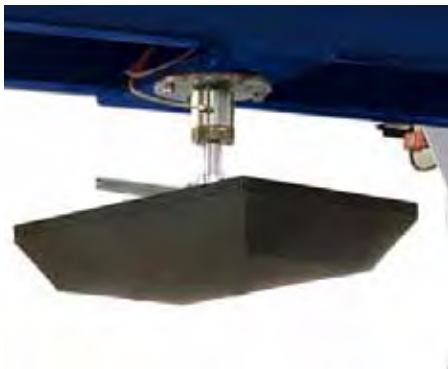

**Pneumatic Pressure Platen**  
Pneumatic Pressure Platen provides downward pressure on top of load to help stabilize package during wrapping process.



**Double Diamond Pressure Platen**  
Double Diamond Pressure Platen allows for a wider range of wrapping height over pneumatic version. It also reduces the amount of head space needed above the machine over the pneumatic model.



# options

## Top Sheet Dispensers



### Inside Dispenser

Patented Inside Top Sheet Dispenser measures and dispenses the correct amount of film on your load during the wrap process and is sandwiched between layers of film to create a water resistant seal.



### Outside Dispenser

Patented Outside Top Sheet Dispenser measures and dispenses the correct amount of film on your load as it is conveyed into the wrapping area to create a dustproof wrap.

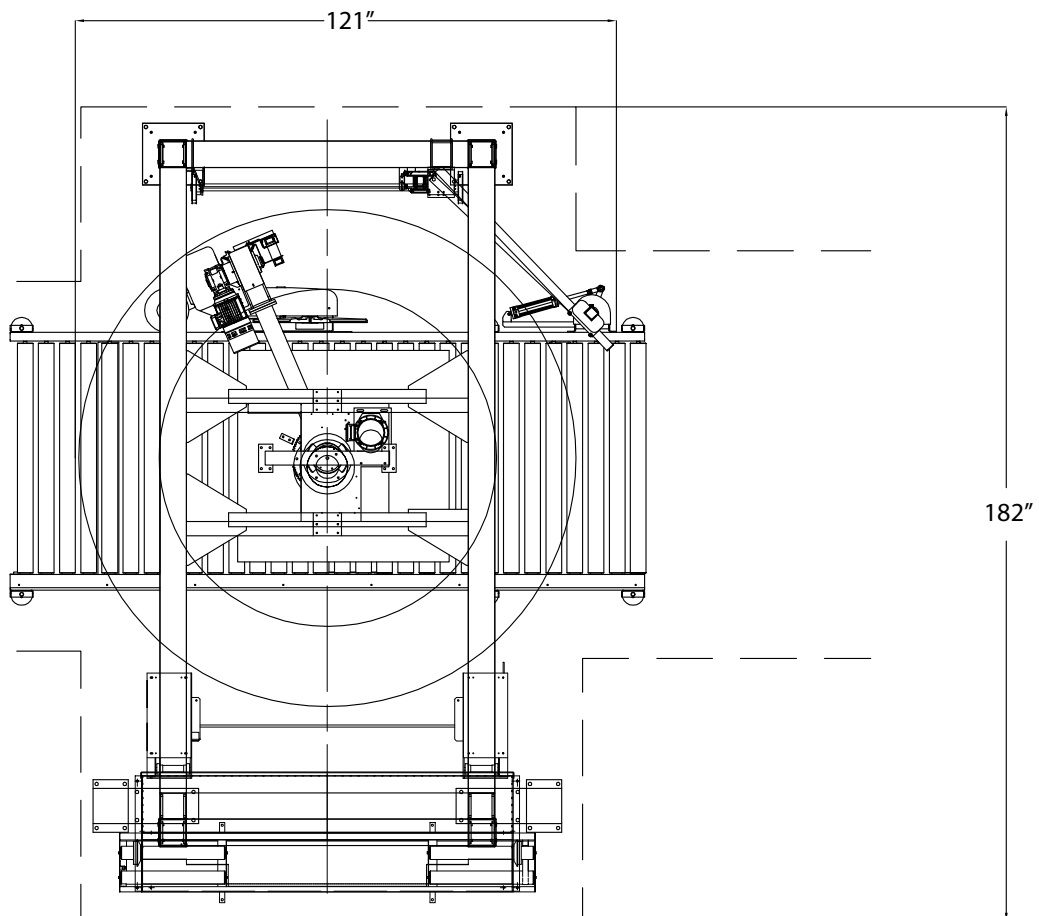

# options

## Pallet Lifter



The pallet lifter raises the pallet during the wrapping process to ensure proper placement of film or rope on a shorter pallet. You can wrap down to the very bottom or even under the pallet, depending on your needs.

## Roping Device

Automatic Roping Devices (Top, Bottom or Top & Bottom) combined with the latest in encoder technology allow you to place either partial or full web ropes of film at key points on the load or around the pallet to increase load stability.

The top and bottom combination roper allows you to wrap cold loads, hot loads, fresh fruits or vegetables, or any type of load that needs to breathe.



## Film Clamping Devices



Ring Clamp



Nipper Clamp for LP-AS Model



Hot Plate Welding Unit