

**ROBOPAC** 

**SEMI AUTOMATIC**

# *Rotoplat 708*

SEMI-AUTOMATIC TURNTABLE STRETCH WRAPPING MACHINE



# Safety

The safety of your operators and employees is of prime importance to us at Robopac. All our equipment is CE Certified. CE represents the strictest and most widely accepted safety and electrical standards in the market. We include safety features like an anti-fall device and roll carriage safety

stop and 65" diamond plated turntable as standard options. Our competitors either don't offer these critical safety features or consider safety optional and charge you hundreds of dollars to rise to our standard of safety.



**1.**  
**ANTI-FALL DEVICE**

The film carriage's anti-fall device protects workers and products in the unlikely event of chain slippage or breakage.



**2.**  
**OPERATOR PROTECTION**

A safety distance of 23" between fixed and moving parts provides an added level of safety for your operators.

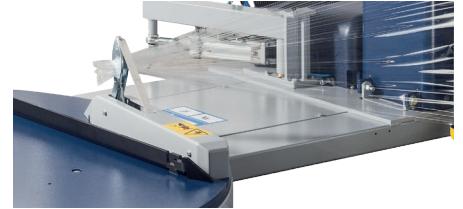

**3.**  
**ROLL CARRIAGE LOCATION**

Roll Carriage is on the operator side of the machine, near the control panel. This keeps the operator out of the wrapping zone when interacting with the load.

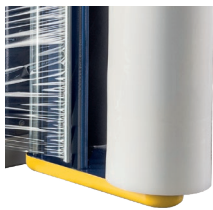

**4.**  
**ROLL CARRIAGE SAFETY STOP**

Immediately stops the roll carriage in the event a person or product contacts the roll carriage as it travels downward. This protects both your people and your product from injury and damage.



**5.**  
**65" DIAMETER DIAMOND PLATE TURNTABLE**

The 65" turntable is made of 3/8" diamond plated steel that prevents your load from shifting, offers added slip resistance when employees step on the turntable and will easily accommodate a 40" x 48" load with no unsafe overhang.



**6.**  
**EMERGENCY STOP**

Large button located prominently on control panel stops all machine operations immediately.

## Popular options



### **NEW Automatic Roping Device**

Roping device attached to roll carriage ropes the entire web of film from the top down. Pneumatic device can be turned on or off at up to 9 different preset locations on each load. Roping from the top allows you to apply a high tensile strength rope of film to the pallet wherever it is needed to improve load integrity. Full web film roping is the best way to lock the load to the pallet.



### **Integrated Scale Package**

Built-in 5,000 lb capacity scale system allows you to wrap and weigh your loads in one easy step. Integrated design increases the height of the turntable by less than 1". Scale is NIST Certified and comes pre-calibrated. Includes digital readout.

### **Automatic Film Cutting Device**

Automatically cuts film at end of wrap cycle, saving operator an estimated 30 seconds per load.

### **Heavy Duty Support**

Additional rollers allow the turntable to support heavier loads to 5,500 lb. Strategic placement keeps turntable top from buckling and reduces wear on parts.

# Roll carriage



## Robopac's Patented Powered Variable Pre-Stretch Roll Carriage

The Rotoplat 708 features an S winding pattern roll carriage with Quick Load System that provides 40% more film contact than the W winding pattern (commonly used by competitors) to provide better control of film through the roll carriage and fewer film breaks.

This innovative, dual motor pre-stretch system provides you the ability to pre-stretch film from 150% up to 400% using two independent, variable AC motors.

Both the pre-stretch and containment force are adjustable via the operator control panel. Robopac's patented high-performance S-Wrap Pattern (with Quick Load System) and load cell corner compensation and containment force device give you total film control.

The Rotoplat 708's variable pre-stretch delivers the best film economy for all films and all loads. Six selectable wrap patterns allow you to optimize each of your load types, reduce damage, improve productivity and reduce film costs.

# Turntable



The Rotoplat 708 turntable is supported by 28 heavy duty casters and can handle loads up to 4,400 lbs. Weight capacity increases to 5,500 lbs by simply adding 16 additional casters. This can be done at order entry or added later in the field.

The heavy duty 65-inch turntable is powered by a full 1 horse power AC motor and is made from 3/8" diamond plated steel. The oversize turntable safely and easily accommodates a 40" X 48" with no overhang. The diamond pattern on the turntable plate ensures better grip on any load to avoid slippage during the wrapping process.

# Standard features



Roll carriage lift motor with encoder, delivers precise placement of the film (within 0.2 inches of setting) when used in CUBE mode.

Photocell automatically detects top of load and utilizes infrared sensors that provide better readings on dark and/or shiny products that can provide false readings with traditional sensors.

NEMA 12 control panel enclosure protects against dust, dirt, fibers and lint. It also protects from dripping water, external condensation and other noncorrosive liquids.

Tubular cold rolled steel mast provides superior rigidity, minimizing torque and flex.

Heavy duty chain provides smooth and accurate carriage travel up and down.  
New heavy duty 1 hp AC motor and gear box ensure years of trouble-free performance.

Forklift portable from both the front and back. Making it safe and easy to place the Rotoplat 708 anywhere in your operation.

CE approved, conforming to global electrical and safety standards.

Control panel is UL508 approved.

# Technical features

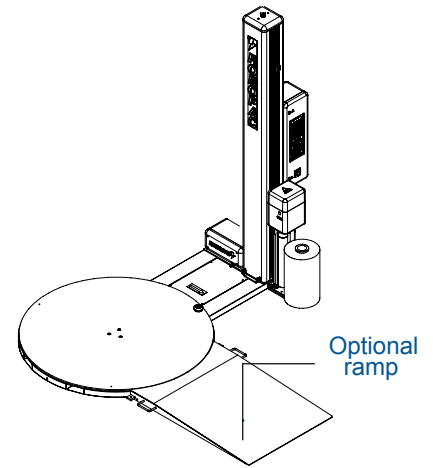
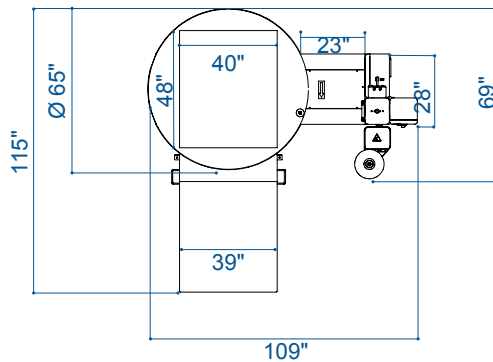
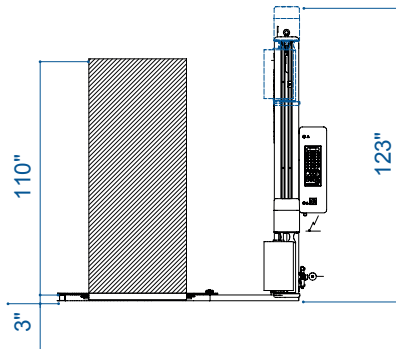

MACHINE		ROTOPLAT 708	
<b>PERFORMANCE</b>			
Production speed	Up to 40	(lph)	
Turntable speed	5-12	(rpm)	
Turntable drive	1 HP	(vac)	
<b>LOAD HANDLING</b>			
Turntable size	65 diameter diamond plated steel	(in)	
Maximum load weight	110	(in)	
Minimum load weight	4.400	(lbs)	
<b>FILM DELIVERY SYSTEM</b>			
Film delivery system		Power variable stretch	
Standard pre-stretch	Variable to 400% with up to 9 different levels per load		
Containment force	Variable electronic with up to 9 different levels per load		
Corner compensation	Load cell		
Roll carriage speed	Variable up and down		
Standard film width	20	(in)	
Automatic film cut	Option		
Load Height Detection	Infrared photocell detects dark, clear and reflective products. Eliminates false reading on gaps in loads.		
<b>SAFETY FEATURES</b>			
Roll carriage safety stop	STD		
CE compliant	Yes		
Anti-fall device	STD		
Lock-Out/Tag-Out Compliant	Yes		
<b>ADDITIONAL FEATURES</b>			
Top sheet wrap	STD		
Banding	STD		
Forklift portable	Front and rear		
<b>SERVICE REQUIREMENTS</b>			
Electric	110VAC/1ph/60Hz (+/-10%)	(vac)	
Pneumatic	60	(psi)	
NEMA 12 enclosure	STD		
Warranty	5 years		

## Features Adjustable via Control Panel

- ▶ TURNTABLE ROTATION SPEED
- ▶ UPWARD/DOWNWARD CARRIAGE SPEED
- ▶ FILM TENSIONING
- ▶ UPWARD/DOWNWARD FORCE TO LOAD
- ▶ PRE-STRETCH RATIO
- ▶ UPWARD/DOWNWARD PRE-STRETCH
- ▶ BOTTOM WRAPS
- ▶ TOP WRAPS
- ▶ WRAPPING START POINT
- ▶ PHOTOCCELL SENSING DELAY

## Wrap Cycles and Custom Programs

- ▶ TOP SHEET CYCLE
- ▶ TOP PLATEN CYCLE  
(TOP PLATEN IS OPTIONAL)
- ▶ REINFORCING WRAP CYCLE
- ▶ 6 USER DEFINED PROGRAMS

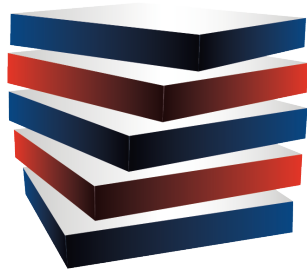

# CUBE™

TECHNOLOGY

## SETTING THE STANDARDS



The key to the success of any activity in the manufacturing environment is setting and holding standards. Stretch wrapping is no exception. To successfully wrap your loads and to ensure that they reach your customer in as-made conditions, it is critical that you set and hold the proper standards for wrapping each of your loads.

Robopac's intuitive 7 inch color touchscreen makes it easy to set up the correct parameters for wrapping each of your loads. You control pre-stretch, containment force, rotation speed, roping and banding at 9 levels on each load.



PRE-STRETCH



FORCE TO LOAD



ROPING



FILM PLACEMENT



ROTATION SPEED

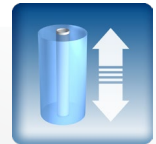

CARRIAGE SPEED



## HOLDING THE STANDARDS

Once you've set your standards, the new Rotoplat 708 makes it simple to hold those standards. Robopac's software allows you to record up to 12 unique wrapping programs.

Lock in the best wrap settings for up to six completely unique load configurations and save them. Your operator can then recall the appropriate program over and over with a touch of the control panel. You can name each program to ensure that your operators always select the correct standard.

Robopac's innovative technology allows you to wrap your loads correctly every time, ensuring ultimate load protection and film savings time after time.



*The goal of CUBE Technology is simple: successfully wrap your loads and ensure that they reach your customer in as-made condition by setting and holding the proper standards for wrapping each of your loads. To achieve this, CUBE Technology addresses four key factors required to successfully wrap your load.*

**Multi-Level Variable Pre-Stretch** ensures the best film economy for every load. It allows you to get the highest containment and the best film economy from any stretch film. You can adjust the pre-stretch up to 9 times on each load. Multi-Level Variable Pre-Stretch Technology delivers 30% to 55% film savings over currently available competitive stretch wrapping systems.

**Multi-Level Variable Containment Force** delivers optimal containment force at each level. Containment force on the Technoplat 708 is adjustable up to 9 times on each load.

**ProActive Corner Compensation** combines the latest in motor and load cell technology to give you the ability to wrap any load securely without crushing the corners of the load. The corner of every load is the biggest constraint to film savings and load containment. Competitive systems deliver 30% to 40% higher containment on the corners of the load than in the middle causing either repetitive film breaks or load failures due to crushing and collapsing the corners of your boxes. Robopac's Technoplat 708 will provide a more consistent containment force across the entire perimeter of the load.

**Strategic Film Placement** allows you to place the film exactly where it has the most impact on load stability and containment. This innovative technology allows you to place bands of film or roped film in critical areas of your loads. Thousands of hours of testing in our lab have shown that putting the film in correct position, with the correct containment force is the key to successfully shipping any product.

**ROBOPAC**  
Innovation driven by values

ROBOPAC U.S.A.  
2150 Boggs Road, Building 200 - Suite 200 - Duluth, GA 30096 USA  
T. (+1) 678 473 7896 - (+1) toll free 866 713 7286  
info@aetnagroupusa.com  
www.robopac.com/US

